

Illustration - Type - E

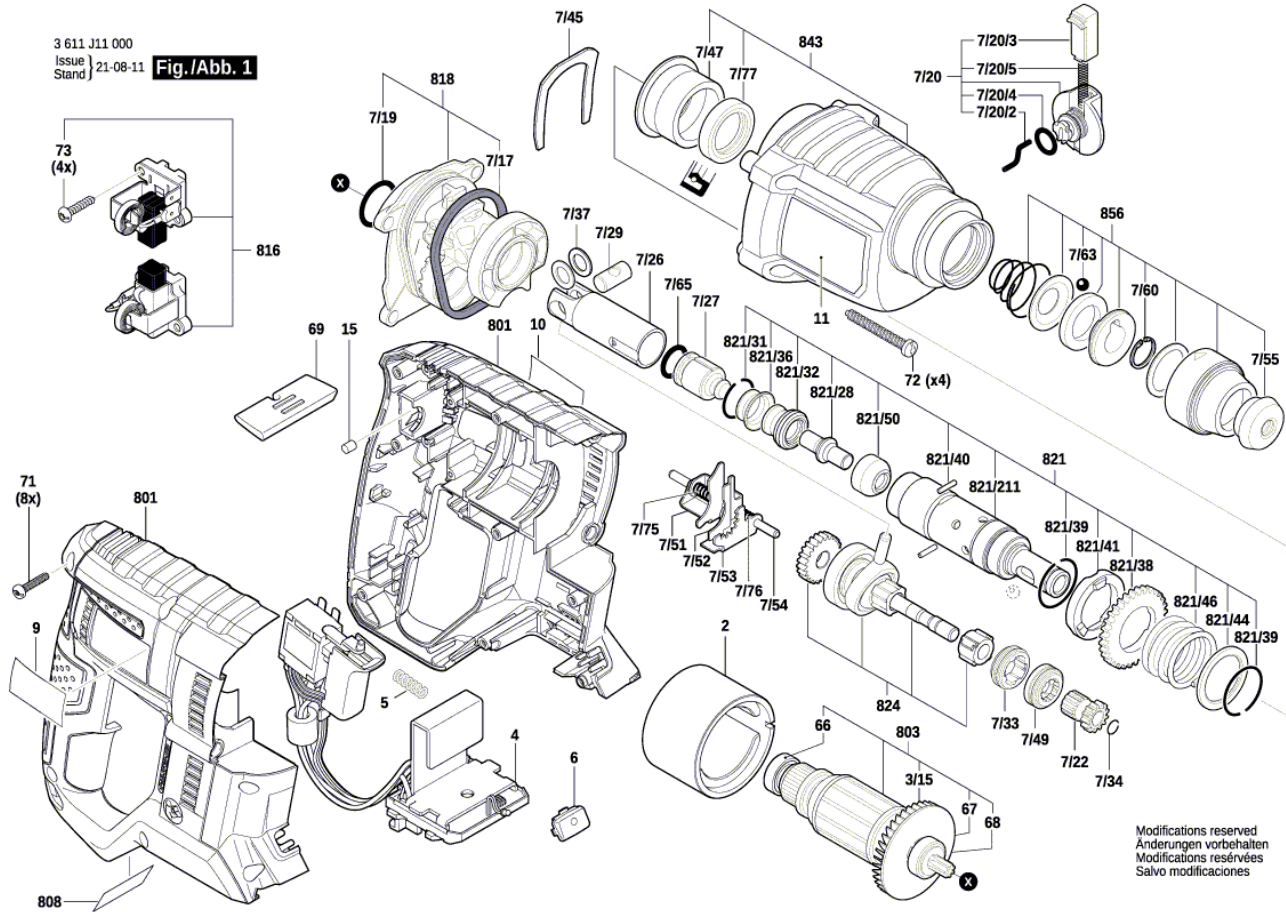
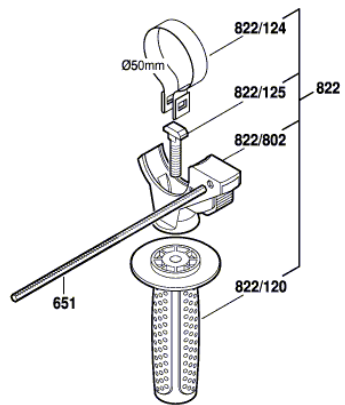

Illustration - Type - E

3 611 J11 000
 Issue | 20-08-19
 Stand | **Fig./Abb. 2**



Pos 7*
 Auslastmoment 28,0 - 8,0 Nm
 Slipping point of clutch 28,0 - 8,0 Nm
 Couple de glissement 28,0 - 8,0 Nm
 Momento de desenchavamiento 28,0 - 8,0 Nm

Anzugsmomente
 Torque values
 Couple de serrage
 Pares de apriete
 Pos. 71 = 1,6 - 2,0 Nm
 72 = 2,2 - 2,7 Nm
 73 = 1,0 - 1,3 Nm
 822/12 = 2,7 - 4,7 Nm

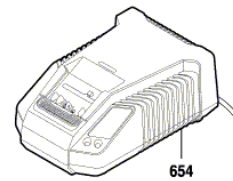
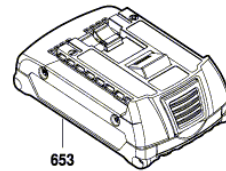
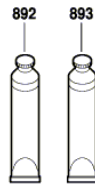
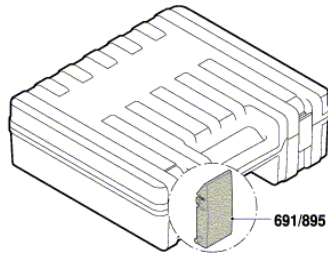

Modifications reserved
 Änderungen vorbehalten
 Modifications réservées
 Salvo modificaciones

Spare parts list

Item	Part Number	Description	Illustration
2	1 619 P13 742	Field	1
3/15	2 610 909 077	axial flow fan	1
4	1 600 A00 F9H	Electronic Module	1
5	2 604 690 055	Compression Spring	1
6	1 619 P13 744	Lens	1
7/17	1 610 290 108	O-Ring	1
7/19	1 610 210 184	O-Ring 22,0x2,5 MM	1
7/20	1 612 026 151	Clamp Handle BLACK	1
7/20/2	1 614 690 009	Driver Pin	1
7/20/3	1 612 026 035	Switch Button RED	1
7/20/4	1 610 210 046	O-Ring 10,5x2,7 MM	1
7/20/5	1 614 611 006	Compression Spring	1
7/22	1 616 328 053	Gear Sleeve	1
7/26	1 618 700 083	Hammer Piston	1
7/27	1 618 710 085	Striker	1
7/29	1 613 100 034	Piston Pin	1
7/33	1 615 820 103	Switching Element	1
7/34	1 619 P00 829	Retaining ring	1
7/37	1 610 100 016	Guide Disc	1
7/45	1 611 016 003	Holding Plate	1
7/47	1 610 202 031	Plain bearing	1
7/49	1 615 820 104	Switching Element	1
7/51	1 610 021 004	Shift Plate	1
7/52	1 610 021 006	Shift Plate	1
7/53	1 610 021 005	Shift Plate	1
7/54	1 613 023 005	Guide Rod	1
7/55	1 610 508 052	Protective Cap	1
7/60	1 614 601 077	Spring retaining ring	1
7/63	1 903 230 013	Ball DIN 5401-Ø7MM-III-ST	1
7/65	1 610 210 244	O-Ring 13,0x3,0 MM	1
7/75	1 614 643 025	Compression Spring	1
7/76	1 614 643 023	Compression Spring	1
7/77	1 619 P09 722	Shaft Seal	1
9	1 619 P13 760	Manufacturer's nameplate GBH 180-LI	1
10	1 619 P13 761	Manufacturer's nameplate GBH 180-LI	1

Spare parts list

Item	Part Number	Description	Illustration
11	1 619 P13 767	Reference Plate	1
15	2 603 100 056	Damping rubber	1
66	1 900 905 029	Ball Bearing 8x22x7	1
67	1 610 905 047	groove ball bearing	1
68	1 600 100 037	Plain Washer	1
69	1 619 P13 747	Change-Over Switch	1
71	2 603 490 023	Torx Oval-Head Screw 4x20	1
72	1 619 P09 645	Torx Oval-Head Screw	1
73	1 619 P06 252	Torx Oval-Head Screw	1
801	1 619 P14 446	Motor Housing	1
803	1 619 P14 346	Armature	1
808	1 619 P14 573	Nameplate	1
816	1 619 P14 345	Carbon-Brush Set	1
818	1 619 P09 616	Intermediate Flange	1
821	1 619 P09 617	Hammer Pipe	1
821/211	1 619 P09 815	Hammer Pipe	1
821/28	1 613 124 084	Striker Pin	1
821/31	1 619 P09 816	Retaining ring	1
821/32	1 619 P07 426	Rubber Bushing	1
821/36	1 610 551 008	Holding Plate	1
821/38	1 616 317 084	Cylindrical Gear	1
821/39	1 614 601 055	Retaining ring	1
821/40	1 613 100 032	Straight Pin	1
821/41	1 610 102 072	Ratchet Disc	1
821/44	1 610 102 092	Friction Washer	1
821/46	1 614 630 003	Compression Spring	1
821/50	1 619 P11 562	Guide Bushing	1
824	1 617 000 6BC	Jack Shaft	1
843	1 619 P09 186	Gear Housing	1
856	1 617 000 6D3	Protection Sleeve	1
651	1 613 001 009	Depth-Gauge SW 6x210 MM	2
653	1 607 A35 0M0	Battery Pack GBA 18V 4.0Ah	2
654	2 607 226 251	Fast Charger EU GAL 18V-40, 230V/10,8V – 18V	2
691/895	1 619 P14 336	Latch	2

Spare parts list

Item	Part Number	Description	Illustration
822	1 602 025 08X	Auxiliary Handle	2
822/120	1 602 025 07H	Auxiliary Handle	2
822/124	1 611 316 021	Clamping Band Ø50 MM	2
822/125	1 613 490 002	T-Head Bolt M8x40 MM	2
822/802	1 617 000 475	Support clamp	2
892	1 615 430 020	Grease Tube 225 ML	2
893	1 615 430 001	Grease Tube 225 ML	2

Illustration - Type - E

3 601 J H9 0E0
 Stand | 22-06
 Issue | 22-10-06

Fig./Abb. 1

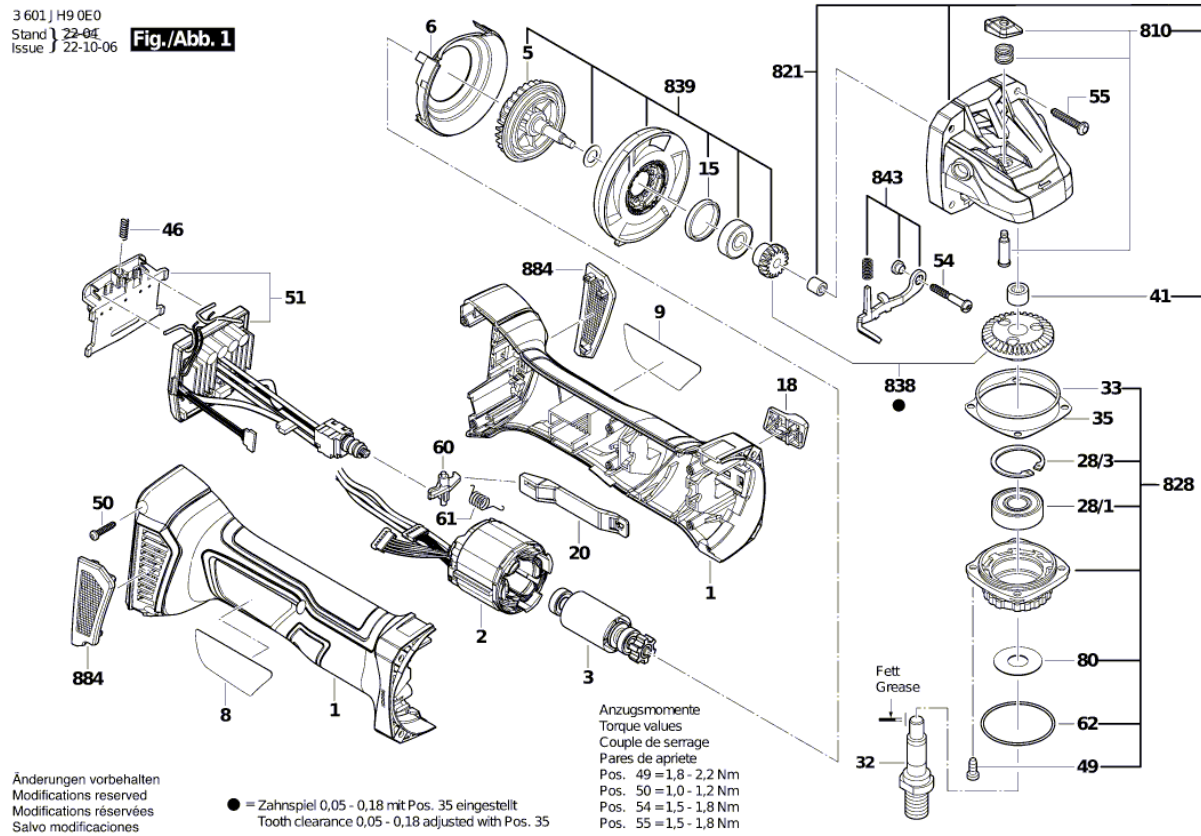
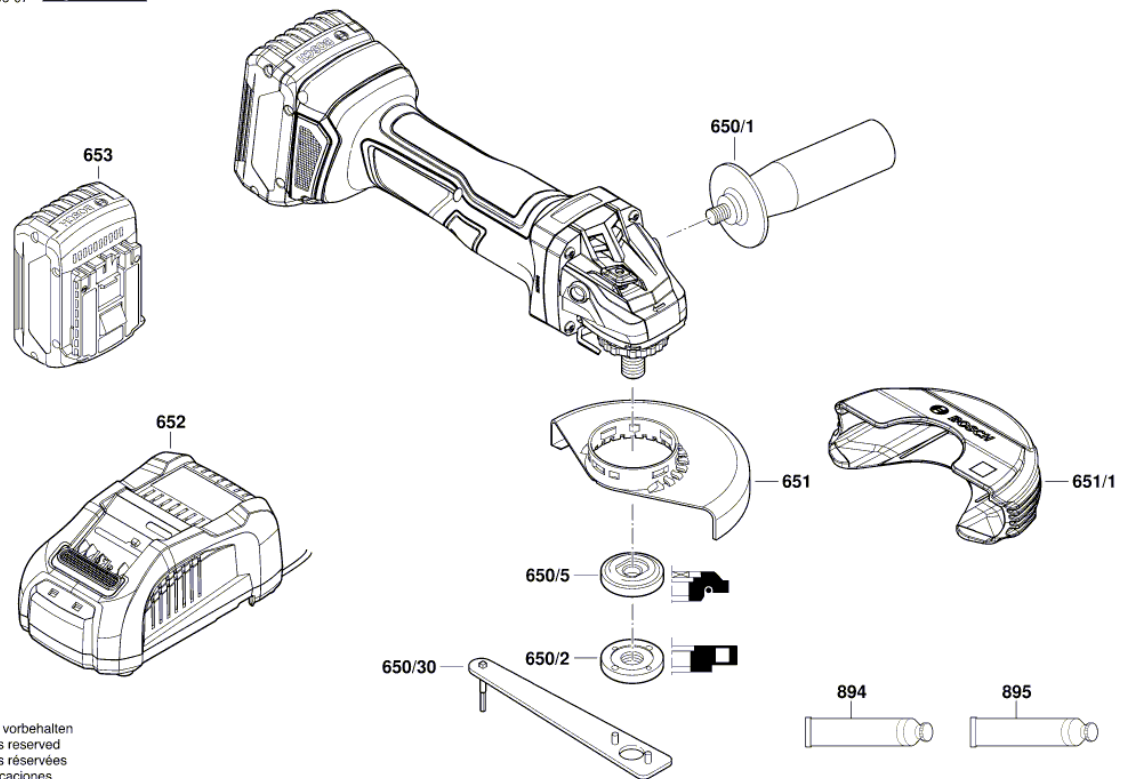

Illustration - Type - E

3 601 JH9 0E0
Stand | 20-11
Issue | 23-06-07 **Fig. /Abb. 2**



Änderungen vorbehalten
Modifications reserved
Modifications réservées
Salvo modificaciones

Spare parts list

Item	Part Number	Description	Illustration
1	1 619 P15 044	Motor Housing	1
2	1 600 A01 A6N	Stator	1
3	1 600 A01 A6S	Rotor	1
5	1 619 P15 054	Fan	1
6	1 619 P16 509	Air-Deflector Ring	1
8	1 619 P15 793	Nameplate	1
9	1 619 P15 781	Manufacturer's nameplate	1
15	1 600 206 025	Rubber Ring	1
18	1 619 P15 338	Switch Handle	1
20	1 619 P15 050	Adjusting Slide	1
28/1	1 619 P07 440	Ball Bearing	1
28/3	2 916 660 013	Retaining clip DIN 472-32x1,2 MM	1
32	1 619 P06 419	Grinding Spindle M 14, SW 17	1
33	1 619 P02 820	O-Ring 44,0x1,0 MM	1
35	1 619 P02 821	Shim 0,1 MM	1
35	1 619 P02 822	Shim 0,2 MM	1
41	1 600 200 029	Plain bearing	1
46	1 609 280 477	Compression Spring	1
49	1 619 P11 118	Thread-forming tap. Screw	1
50	2 609 110 201	Torx Flat-Head Screw 3x16	1
51	1 600 A01 NC3	Electronics Module	1
54	2 603 490 025	Torx Oval-Head Screw 4x30	1
55	1 619 P01 066	Torx Oval-Head Screw 4x25	1
60	1 619 P15 795	Reverse-Transfer Lever	1
61	1 619 P15 806	Torsion Spring	1
62	1 600 210 038	O-Ring 38,0x1,5 MM	1
80	1 619 P09 390	Cover Disc	1
810	1 619 P16 236	Push Button	1
821	1 619 P16 237	Gear Housing	1
828	1 619 P11 098	Bearing Flange	1
838	1 619 P16 240	Gear Unit	1
839	1 619 P16 234	Bevel Gear Shaft	1
843	1 619 P11 076	Catch Lever	1
884	1 607 000 CA9	Filter Unit	1
650/1	1 619 P10 681	Auxiliary Handle	2

Spare parts list

Item	Part Number	Description	Illustration
650/1	1 619 P16 111	Auxiliary Handle	2
650/2	1 603 345 043	Round Nut M14	2
650/30	1 619 P08 927	Pin-Type Face-Wrench	2
650/5	2 605 703 014	Clamping Flange Ø22,3xØ42 MM	2
651	1 619 P14 539	Protective Cover Ø125 MM SILVER	2
651/1	1 600 A02 1MH	Protective Cover	2
652	2 607 225 921	Charger EU GAL 1880 CV 230/14,4-18V	2
652	2 607 226 251	Fast Charger EU GAL 18V-40, 230V/10,8V – 18V	2
653	1 607 A35 0M0	Battery Pack GBA 18V 4.0Ah	2
653	1 607 A35 0MN	Battery Pack GBA 18V 2.0Ah	2
653	2 607 337 069	Battery Pack BBS MR, 18V, 5,0 Ah 48 S	2
894	1 615 430 020	Grease Tube 225 ML	2
895	1 605 430 003	Grease Tube 225 ML	2